

BẢNG KÊ NGUYÊN VẬT LIỆU

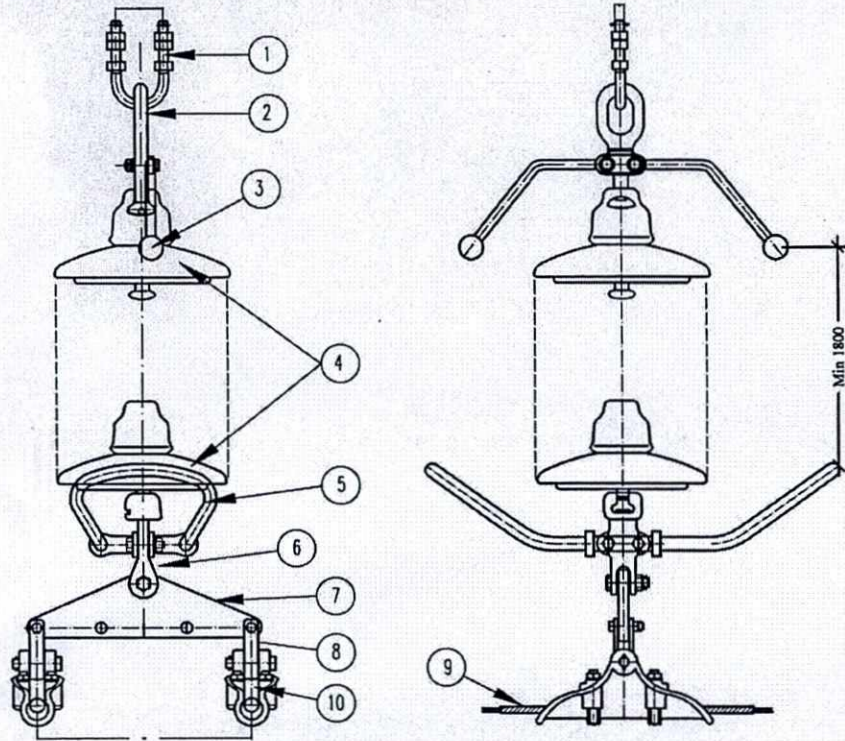

Số TT	Tên phụ kiện	Tải trọng phá hoại	Số lượng	Vật liệu chế tạo
1	Bu lông U	120	01	Hiện hữu
2	Vòng treo đầu tròn	120	01	Hiện hữu
3	Mó phóng		01	Thép mạ kẽm - Thay mới
4	Cách điện U120BP	120	15	Gốm/thủy tinh - Thay mới
5	Vòng đẳng thế		01	Thép mạ kẽm - Thay mới
6	Mắt nối	120	01	Hiện hữu
7	Khánh	120	01	Hiện hữu
8	Mắt nối	120	02	Hiện hữu
9	Đệm dây		02	Hiện hữu
10	Khóa đỡ dây dẫn	120	02	Hiện hữu

Ghi chú:

- Tất cả các kích thước tính bằng đơn vị mm
- Tải trọng chuỗi cách điện là 120kN
- Số lượng bát: 15 bát loại U120BP đang tính toán với dòng dò bát là 440mm/kV
- Chuỗi cách điện sử dụng cho dây dẫn 2xACSR 400/51

Dòng dò quy định (mm/kV)	Ký hiệu cách điện	Tổng chiều dài đường dò (mm)
25	DDD.1-120	6600

CÔNG TY TRUYỀN TẢI ĐIỆN 1  
TRUYỀN TẢI ĐIỆN NINH BÌNH

ĐƯỜNG DÂY 220KV  
THÁI BÌNH - TIỀN HẢI - TRỰC NINH

P.Giám đốc Đỗ Đình Dũng

Kiểm tra Lê Xuân Tú

Ngư: Đỗ Xuân Điền

CHUỖI ĐỒ ĐƠN DÂY DẪN: DDD.1.120

THIS DRAWING IS THE PROPERTY OF "TAG CORPORATION" AND SHOULD NOT BE COPIED OR REPRODUCED WITHOUT PROPER AUTHORIZATION.

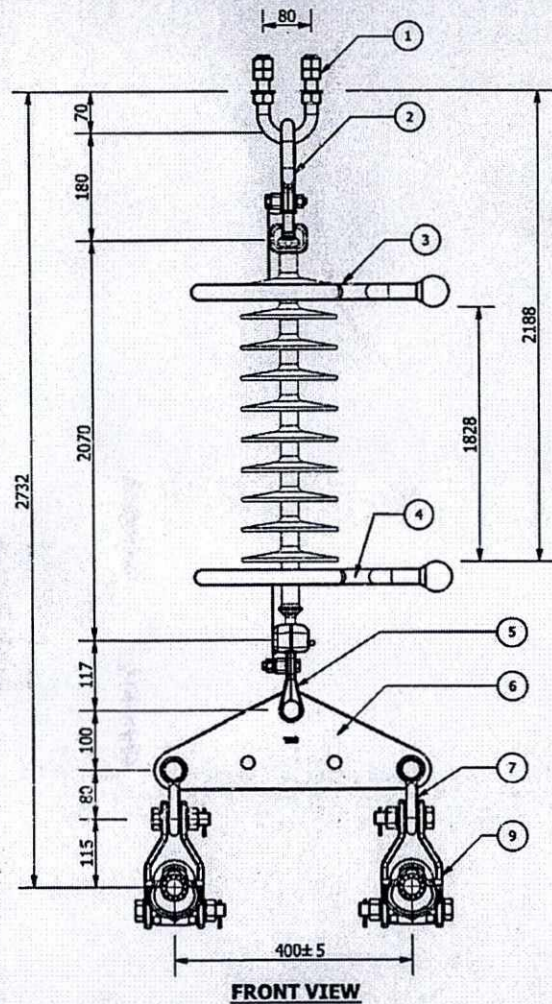

FRONT VIEW

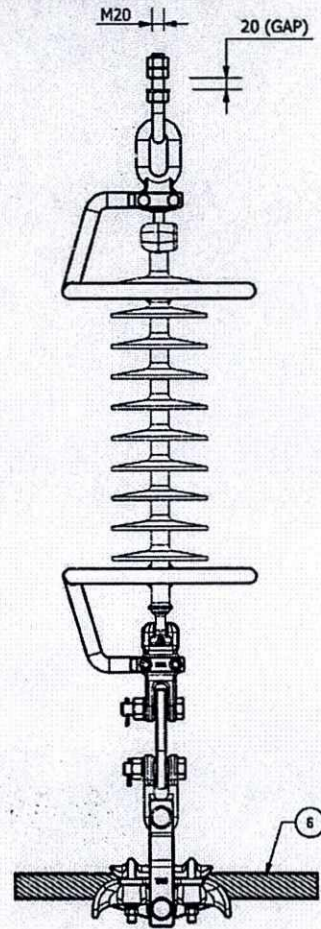

LEFT VIEW

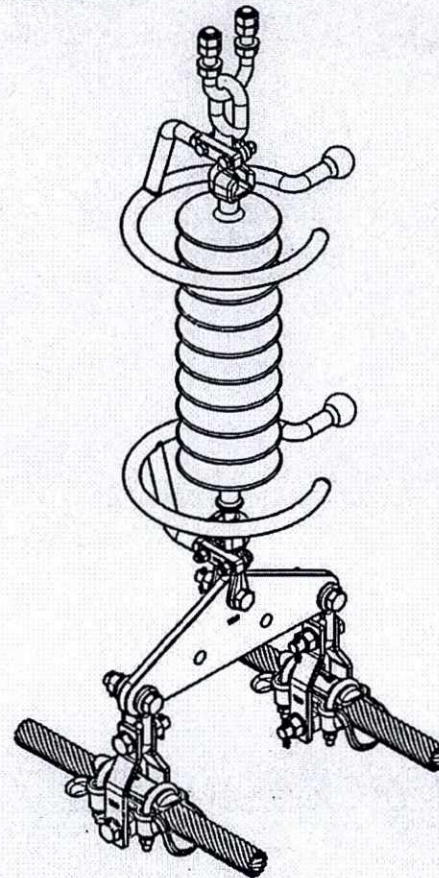

ISO VIEW

ITEM CODE F 0 0 2 3 8 0 0 1

TECHNICAL DATA

1. ASSEMBLY MINIMUM ULTIMATE TENSILE STRENGTH - 120 kN.
2. BALL & SOCKET DESIGNATION - 16MM AS PER IEC - 120.
3. BALL & SOCKET LOCKING BY R-CLIP AS PER IEC-372.  
MADE OF STAINLESS STEEL.
4. FERROUS PARTS - HOT DIP GALVANIZED AS PER ISO 1461.
5. GENERAL TOLERANCE UNLESS OTHERWISE SPECIFIED IS ±3%.
6. TOLERANCE ON LENGTH OF HARDWARE IS ±2%.
7. HARDWARE SUITABLE FOR ACSR/Mz 400/51 (φ27.6) CONDUCTOR .
8. COMPOSITE INSULATOR NOT IN TAG'S SCOPE OF SUPPLY.
9. WEIGHT OF THE STRING - 38.94 kg (APPROX).
10. WEIGHTS INDICATIVE ONLY.
11. ALL DIMENSIONS ARE IN mm.
12. SHORT CIRCUIT CURRENT CAPACITY : 41.1 kA / 1 Sec (Maximum).

REF. DRG.NO: DDD.1.120

Project Name	Package 03: Supply and transport of insulators and fittings, OPGW cable and accessories for 220kV Thai Binh - Tien Hai - Truc Ninh double circuit transmission line
P.O.Ref.No.	-
Purchaser	M/s. NPMB
Contractor	M/s.
Manufacturer	TAG CORPORATION, CHENNAI.

PRODUCT CODE: SSI/T2/LJ

SL.NO	DESCRIPTION	MATERIAL	DRG. NO	COMP.CODE	ITEM CODE	UTS	QTY (NOS.)
9	TRUNNION SUSPENSION CLAMP	AL.ALLOY / GALV.STEEL	SCS4000A	SCS4000A	G00259017	120	2
8	P.A.ROADS	ALUMINIUM ALLOY	PAR/400/51	PAR/400/51	G00241008	-	2 SETS
7	CLEVIS EYE	GALVANIZED STEEL	CE1602	CE1602	G00209012	120	2
6	TRIANGULAR YOKE PLATE	GALVANIZED STEEL	TYP4039	TYP4039	M00608198	120	1
5	H.H. SOCKET CLEVIS	GALVANIZED STEEL	HSC1602.1	HSC1602.1	G00223035	120	1
4	RING TYPE ARCING HORN	GALVANIZED STEEL	RTAH4203	RTAH4203	M00609108	-	1
3	RING TYPE ARCING HORN	GALVANIZED STEEL	RTAH4202	RTAH4202	M00609107	-	1
2	H.H. BALL LINK	GALVANIZED STEEL	HBL3000.2	HBL3000.2	G00217020	120	1
1	U BOLT	GALVANIZED STEEL	UB2001	UB2001	G00266006	120	1

BILL OF MATERIAL

2	08.12.2016	ITEM CODE, PRODC CODE, COMP.CODE ADDED	
1	18.10.2016	(ITEM NO : 3 & 4) NEW ARCING HORNS ADDED	
REV	DATE	DESCRIPTION	APP. BY
REVISION HISTORY			

ITEM NAME:  
220 kV SINGLE SUSPENSION "I" STRING FOR TWIN ACSR/Mz φ27.6 CONDUCTOR

DRG.NO: TAG/E/SSI/T2/LJ	DATE	07.09.2016
	DRAWN BY	P.R.B
	CKD. BY	R.M
	APP. BY	V.T.C
TAG CORPORATION CHROMEPET, CHENNAI - 600 044 EXPORT TAMILNADU, INDIA.		SCALE: 1 : 8

THIS DRAWING IS THE PROPERTY OF "TAG CORPORATION" AND SHOULD NOT BE COPIED OR REPRODUCED WITHOUT PROPER AUTHORIZATION.

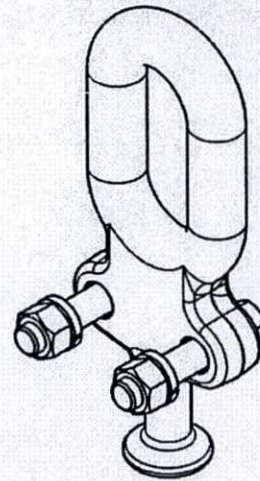
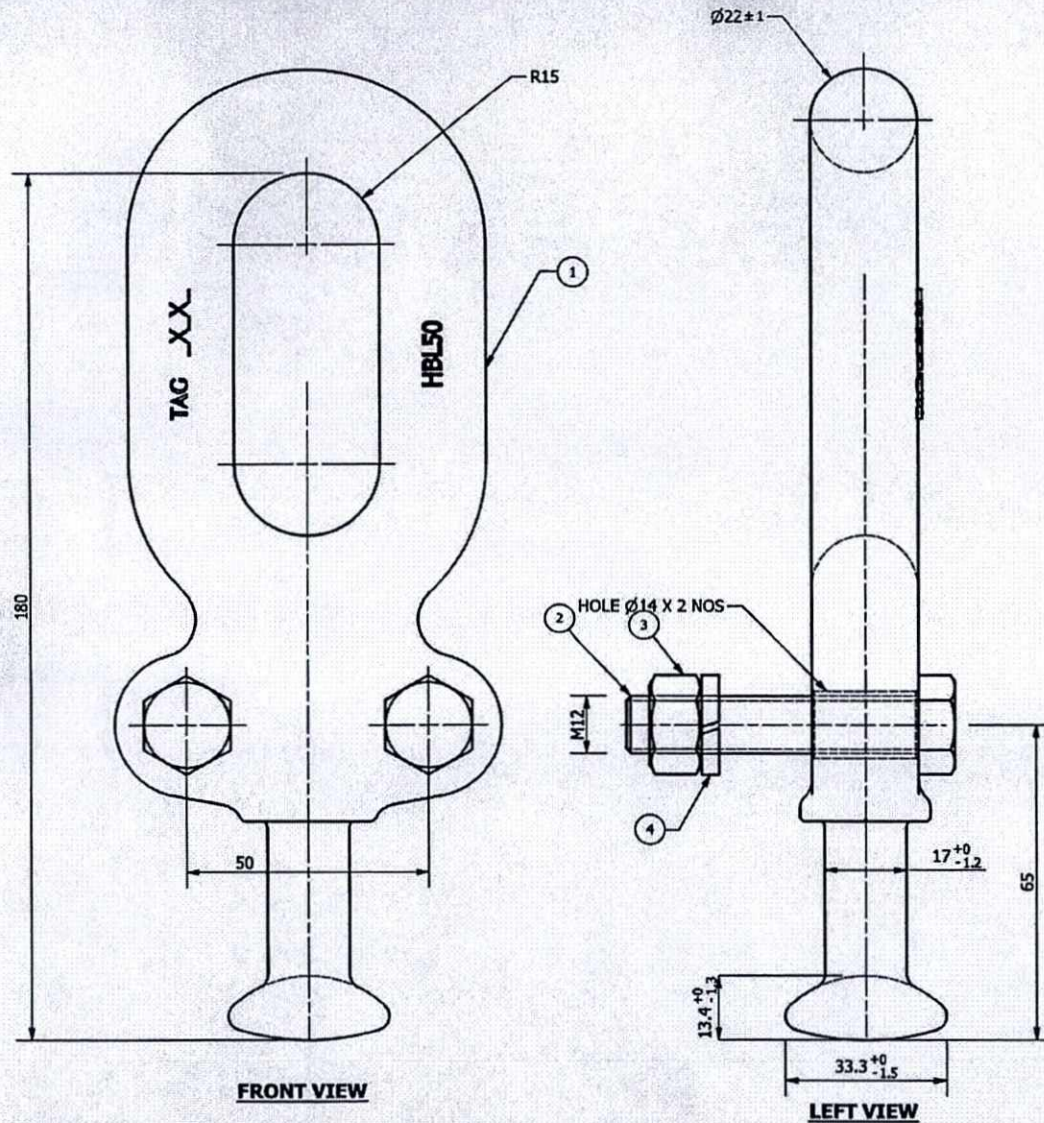

ISO VIEW

ITEM CODE G 0 0 2 1 7 0 2 0

**TECHNICAL DATA**

1. HOT DIP GALVANIZED AS PER ISO : 1461.
2. BREAKING STRENGTH - 120 KN
3. BALL DESIGNATION 16 mm AS PER IEC-120.
4. GENERAL TOLERANCE UNLESS OTHERWISE SPECIFIED IS ±3%.
5. TOTAL WEIGHT - 1.47 kg
6. WEIGHT IS INDICATIVE ONLY.
7. ALL DIMENSIONS ARE IN MM.

Project Name Package 03: Supply and transport of insulators and fittings, OPGW cable and accessories for 220kV Thai Binh - Tien Hai - Truc Ninh double circuit transmission line

P.O.Ref.No. -

Purchaser M/s. NPMB

Contractor M/s.

Manufacturer TAG CORPORATION, CHENNAI.

REV	DATE	DESCRIPTION	APP. BY
REVISION HISTORY			

ITEM NAME: H.H. BALL LINK

DRG.NO: HBL3000.2 DATE 01.12.2016

TAG CORPORATION  
CHROMEPET, CHENNAI - 600 044  
EXPORT TAMILNADU, INDIA.

DRAWN BY P.P  
CKD. BY R.M  
APP. BY V.T.C  
SCALE: 1:1

ITEM	DESCRIPTION	MATERIAL	ITEM CODE	UTS	QTY (NOS.)
4	SPRING WASHER (M12)	SPRING STEEL	B00211002	-	2
3	NUT (M12)	GALVANIZED STEEL (P.C.5.0)	-	-	2
2	BOLT (M12X60)-FT	GALVANIZED STEEL (P.C.5.5)	B00202013	-	2
1	H.H. BALL LINK	GALVANIZED STEEL	M00505005	120	1

**BILL OF MATERIAL**

